

1. Place worksurface on soft, clean, scratch resistant surface with the pilot holes facing upwards.
2. Place End leg (UL) and Center leg (PL) onto the underside of worksurface. Align the holes on the leg plate with the metal inserts in the worksurface.
3. Secure the legs in place by inserting the 1/4-20 x 5/8" Bolts provided through the leg brackets and into the threaded inserts located in the underside of the surfaces.

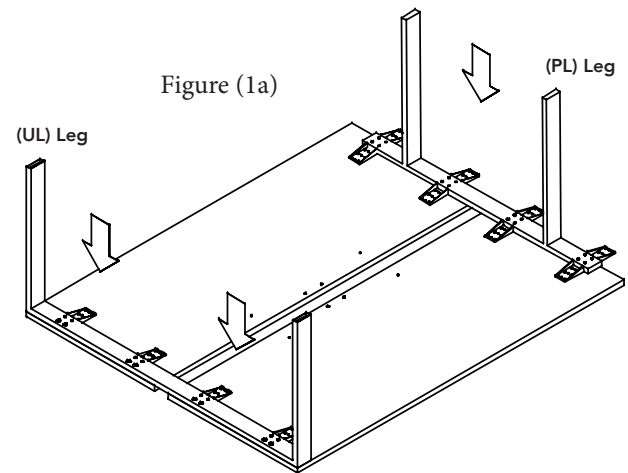

4. Align the stiffener bar with the pilot holes, as shown in figure (2a).
5. Install #10 x 5/8" long wood screws into the pilot hole locations, as shown in figure (2a). Continue to install #10 x 5/8" long wood screws into the remaining stiffener bar hole locations.

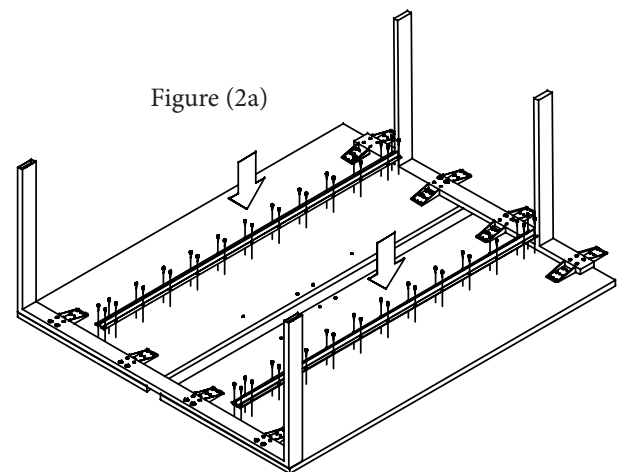

6. Place table into upright position as shown in figure (3a). Two persons are required to place table in upright position.

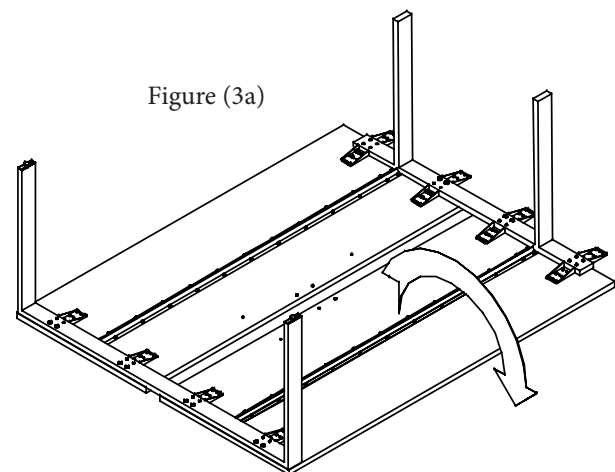

- Assemble the second half of the quad workstation setup with one End Leg (UL) and two worksurface stiffeners (one stiffener per surface) as described in steps 1 through 6.  
Note: the second half of the quad workstation setup does not require a center leg as this is a shared leg.

- Joining the two halves of the quad workstation setup together and fasten the center leg (PL) in place using the 1/4-20 x 5/8" Bolts provided.

Figure (4a)

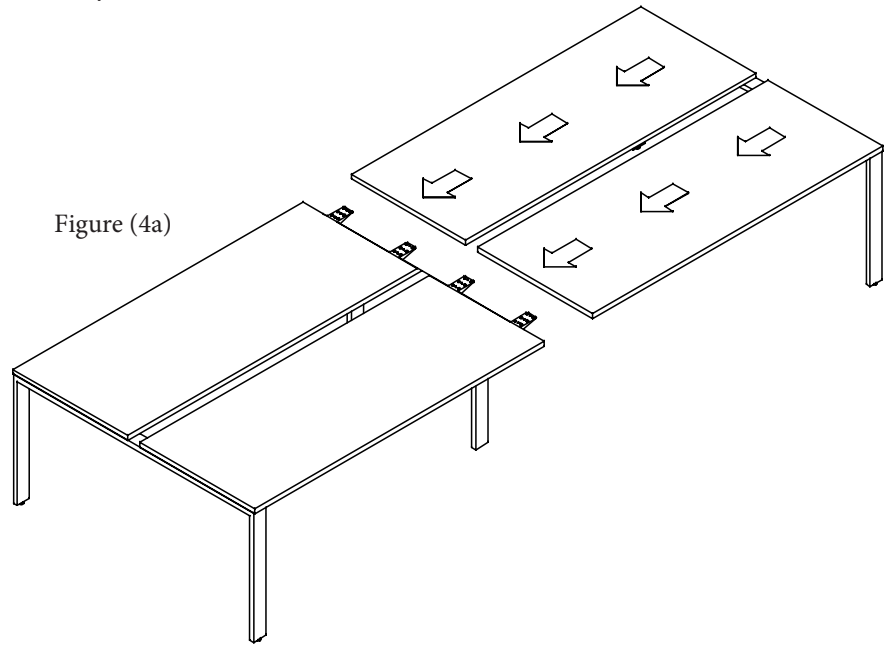

- Install the brackets that will hold your acrylic screen under the worksurface and into the inserts located on the underside of the top using the 1/4-20 x 5/8" Bolts provided.

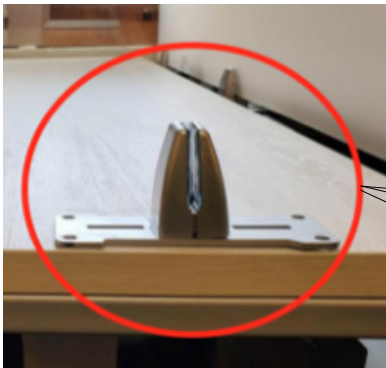
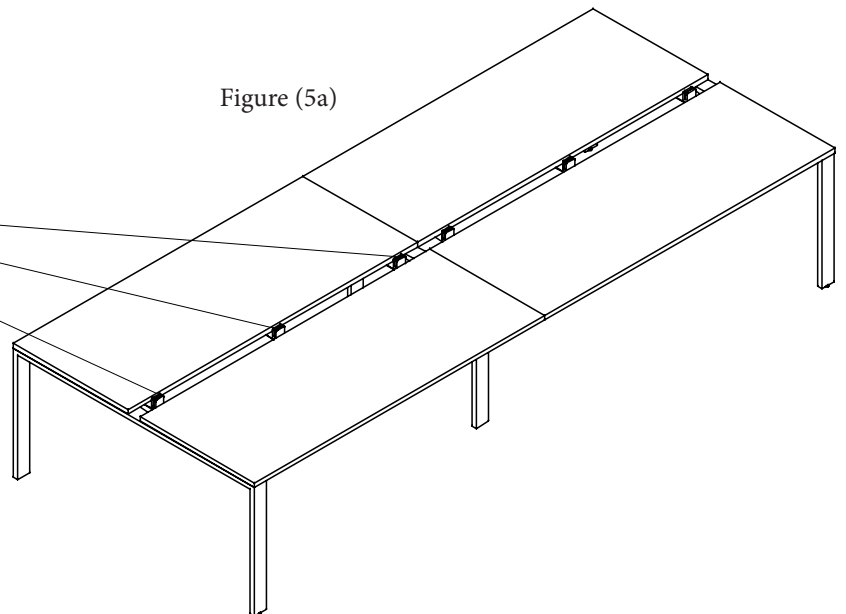

Figure (5a)



10. Insert the acrylic into the glass clips

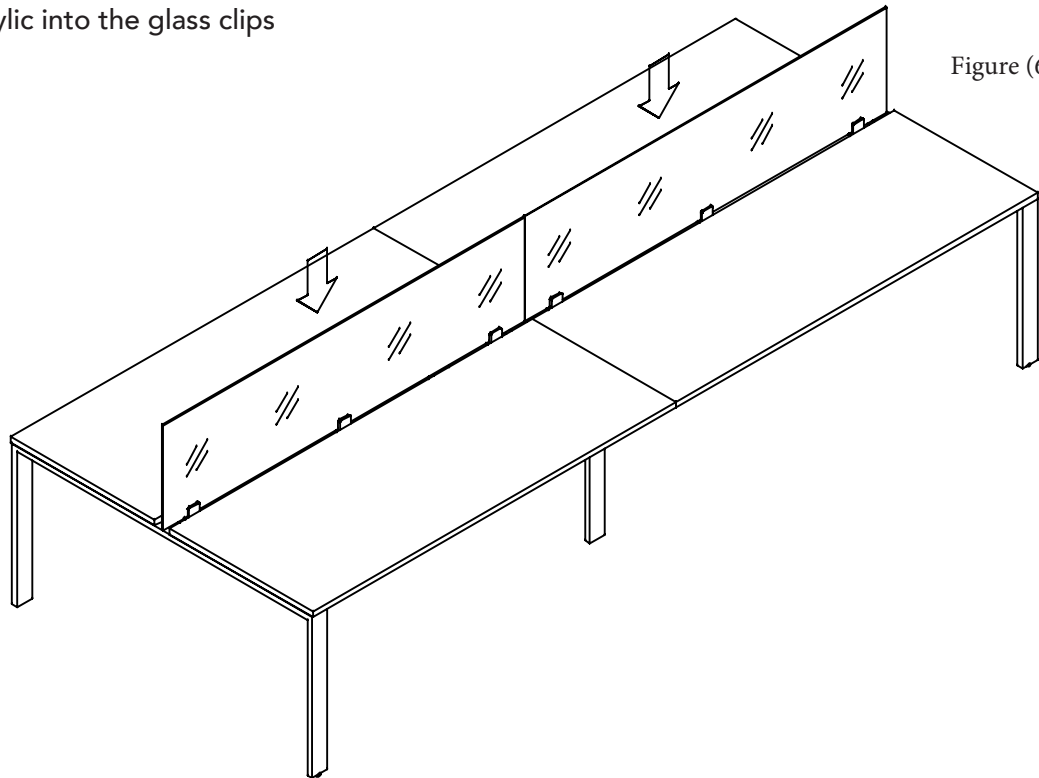

Figure (6a)

11. To tighten the acrylic go to the underside of the worksurface and tighten the bolt located on the glass clip using a 3/16" Ball End Allen Key.

The 3/16" Ball End Allen Key will go under the worksurface and through the cutout in the bracket in order to access the bolt on the glass clip. See illustrations below:



12. If a power module harness is specified, install this item into the inserts located on the underside of the surface using the 1/4-20 x 5/8" Bolts provided.
13. If a wire management tray is specified, install this item into the pilot holes located in the underside of the surface using the #10/12 x 1" long wood screws provided.

