

2EB-DFP DUAL ENCLOSED SHROUD BASE ASSEMBLY

This unit is comprised of 7 main components

1. QTY 1 x Top Worsurface
2. QTY 2 x Upper Bases
3. QTY 2 x Lower Bases
4. QTY 1 x Outer Panel
5. QTY 1 x Inner Panel



2EB-DFP DUAL ENCLOSED SHROUD BASE ASSEMBLY

STEP 1

Place the worksurface face down on a soft, clean surface.

Install the height adjustable table base onto the surface using the pilot holes provided. It is critical that the adjustable base is installed accurately into the pilot holes otherwise alignment issues will occur in later installation steps.

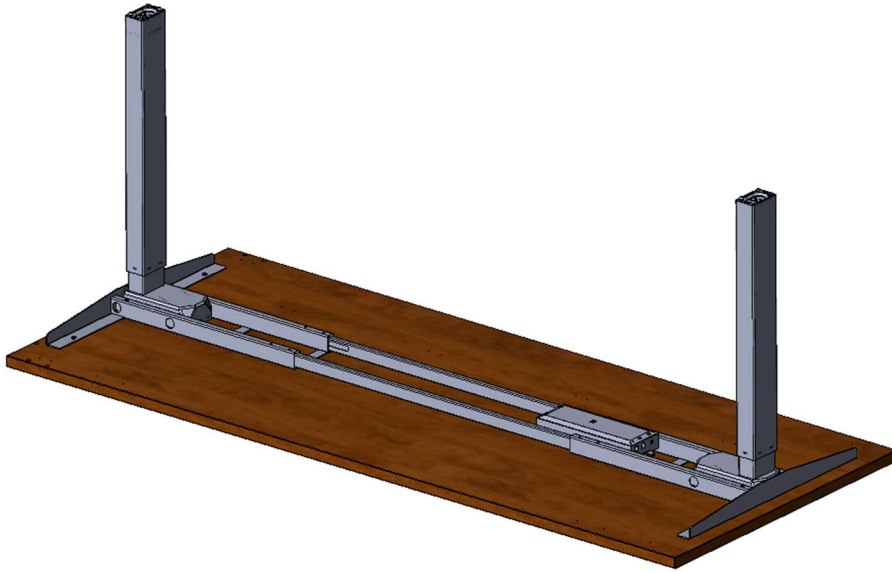

Do not install the height adjustable tables feet onto the columns yet.



STEP 2

Position the **Upper Bases** onto the surface as shown below. Do not fasten them in place.

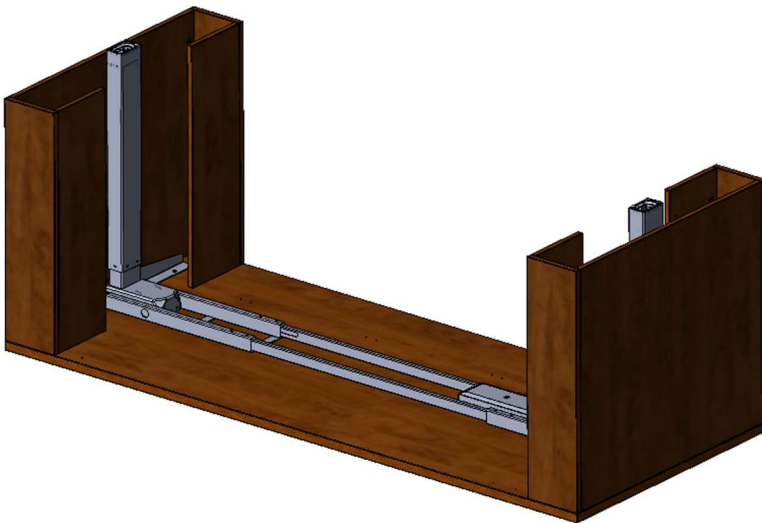
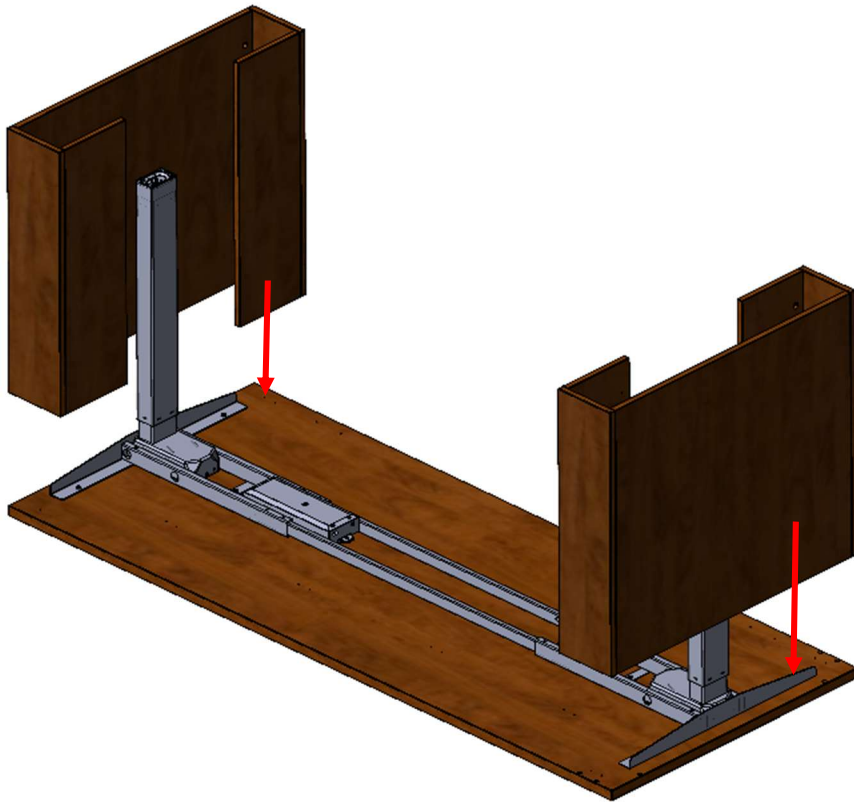

STEP 3

Attach the **Outer Back Panel** between the two upper bases. The back panel should be recessed approximately 6" as shown below

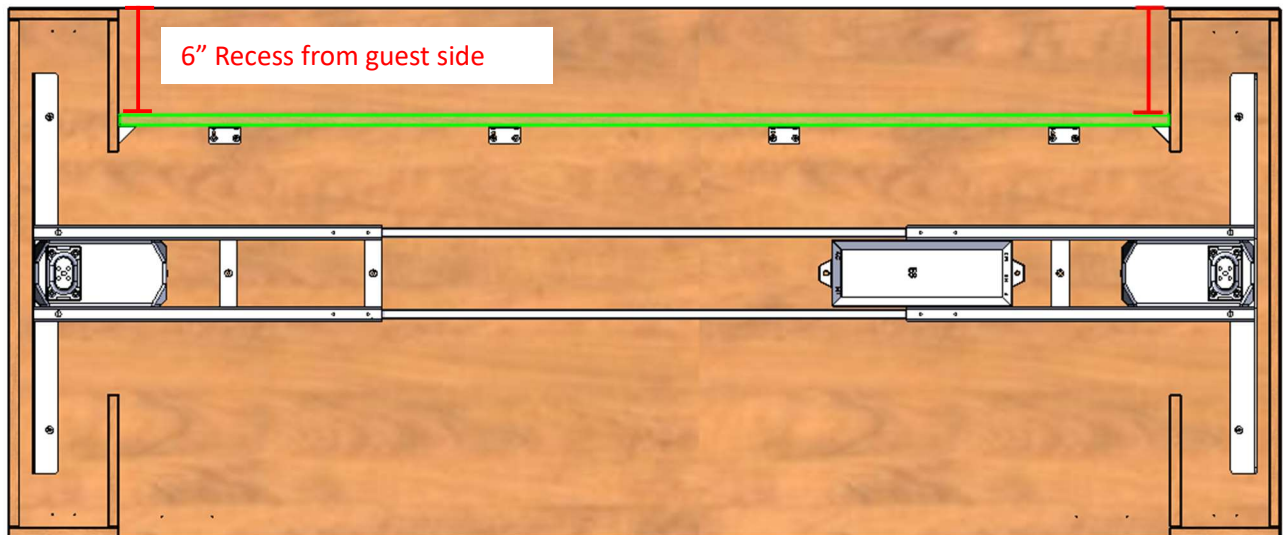
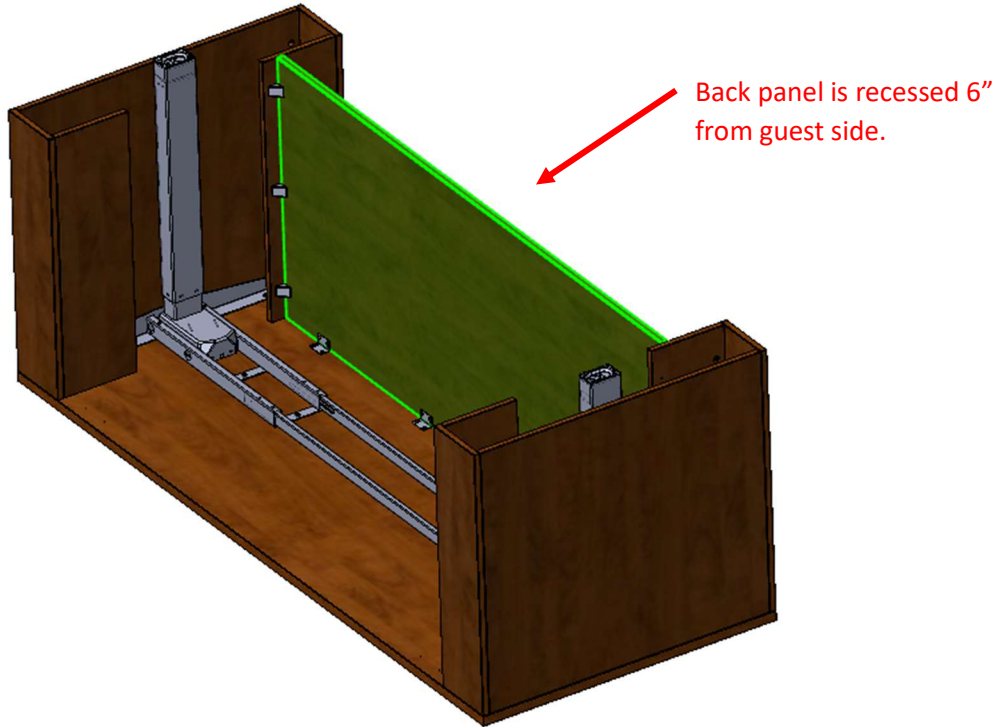

Once positioned, attach the outer back panel to the upper shroud bases using the black plastic corner brackets and wood screws provided.

2EB-DFP DUAL ENCLOSED SHROUD BASE ASSEMBLY

STEP 4

Secure both the outer back panel and the two upper shroud bases to the top surface using the L-Brackets and wood screws provided.

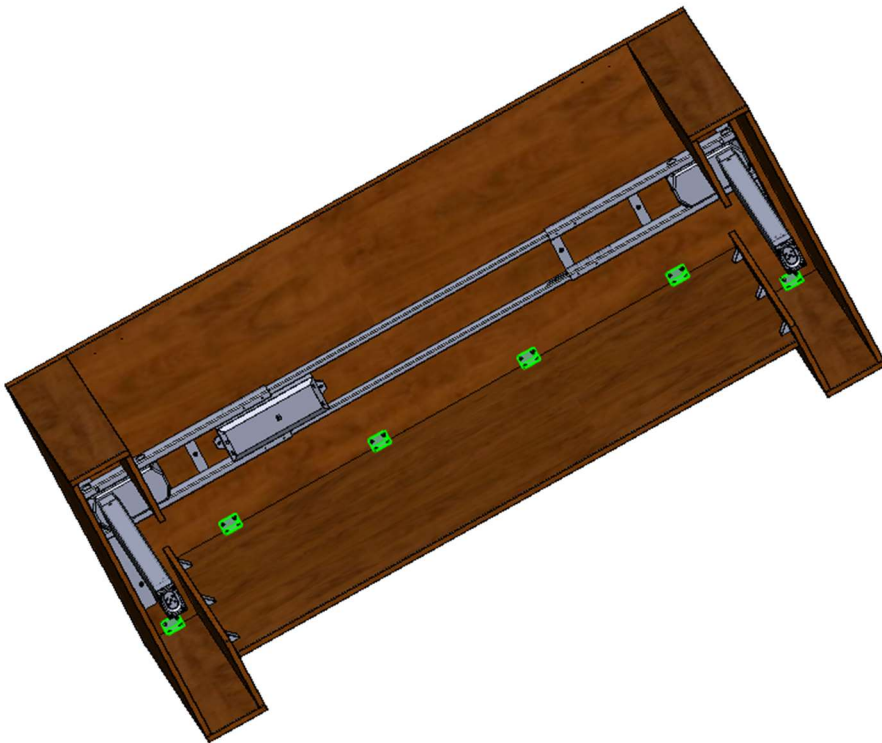
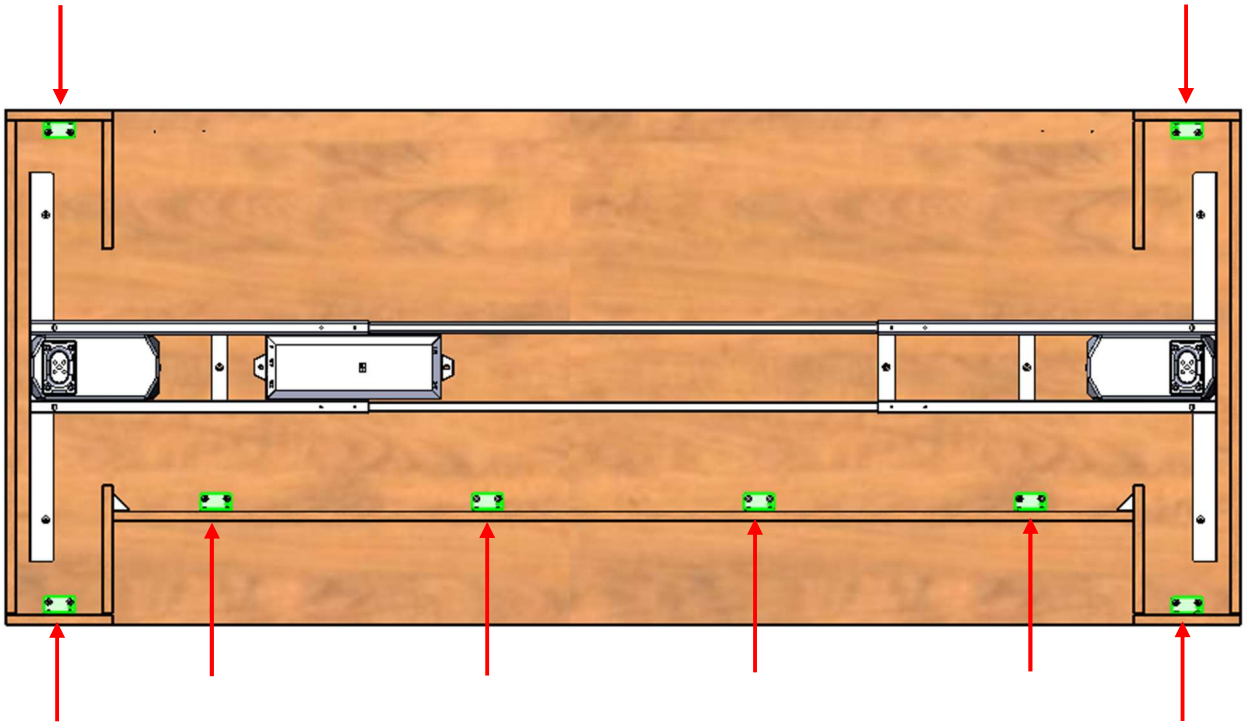

2EB-DFP DUAL ENCLOSED SHROUD BASE ASSEMBLY

STEP 5

Gently slide the lower shroud bases through the height adjustable table columns.

Make sure the lower shroud bases are positioned correctly. The bottom of the bases will have a recessed laminate insert as shown below.

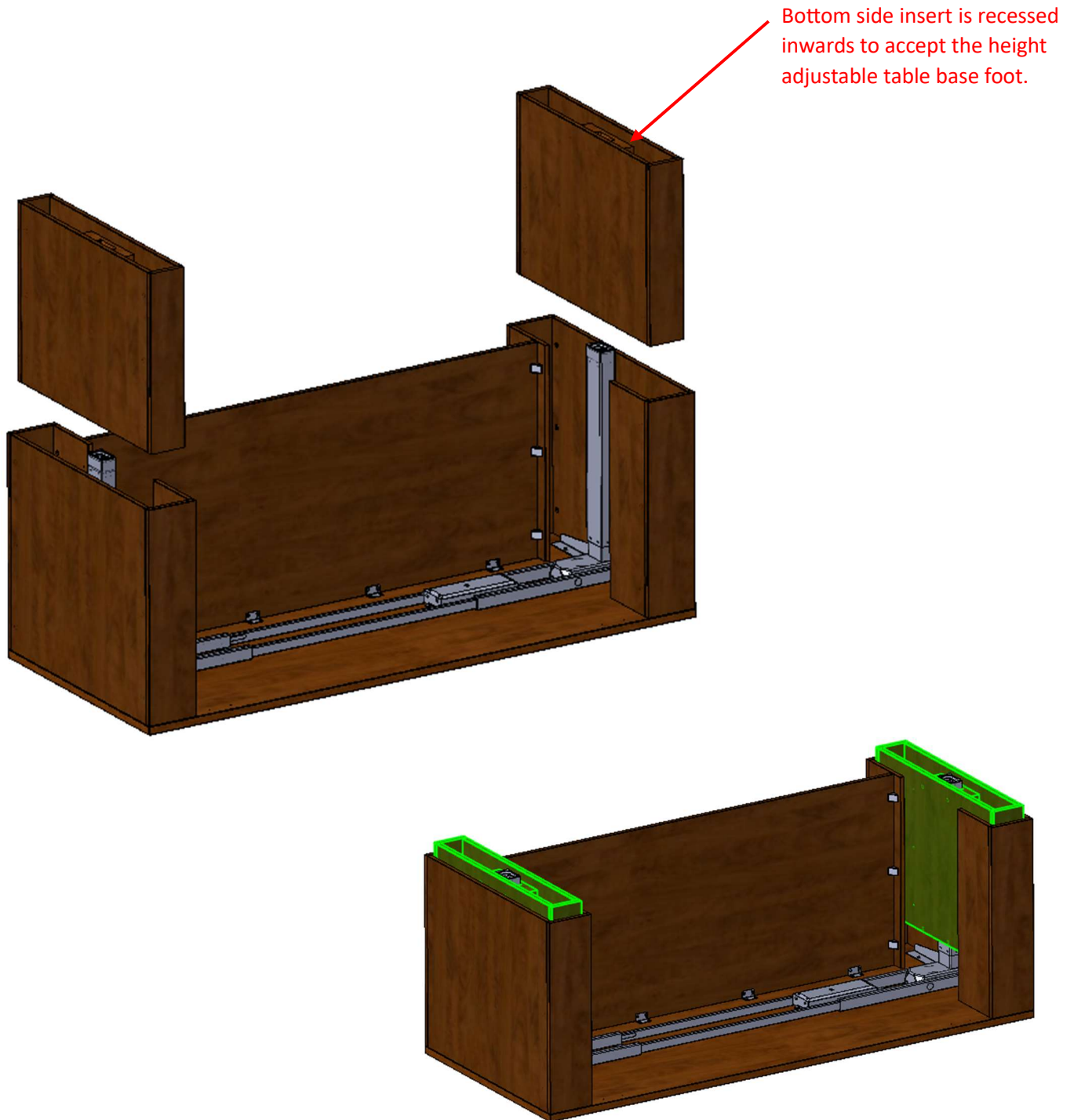

2EB-DFP DUAL ENCLOSED SHROUD BASE ASSEMBLY

STEP 6

Attach the feet onto the height adjustable base.

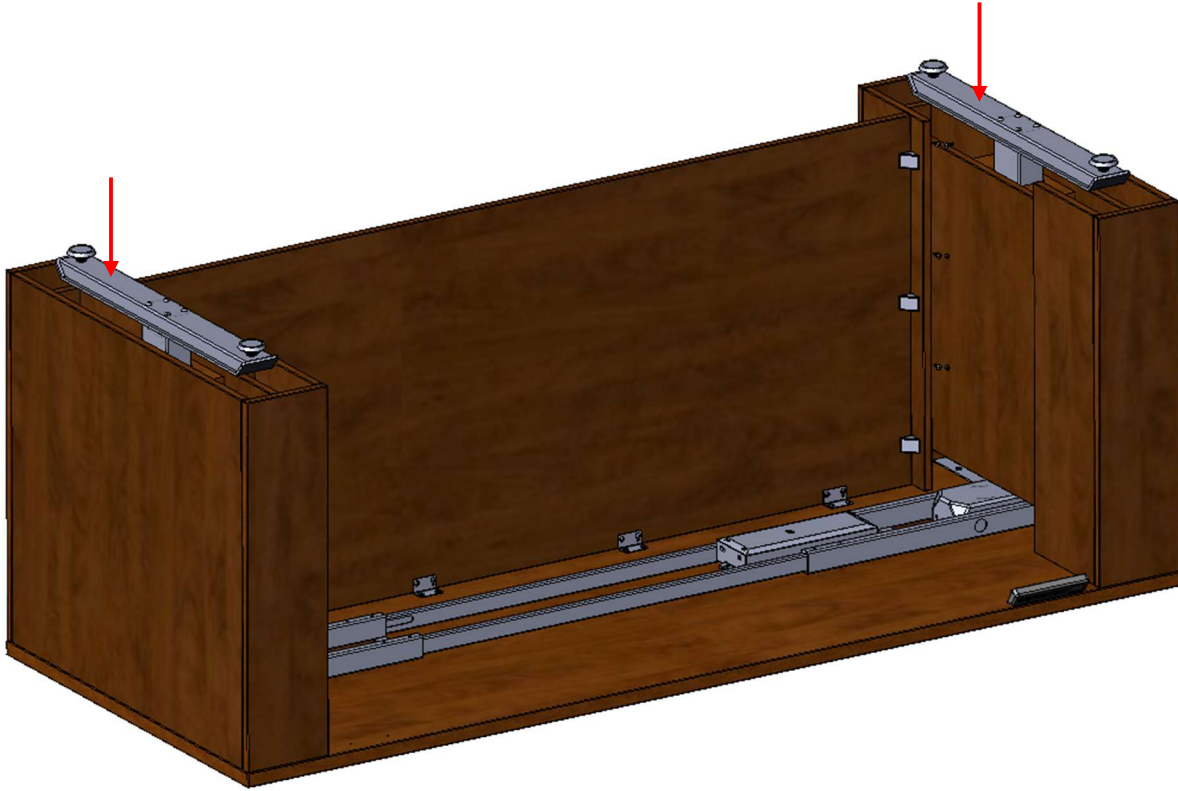

2EB-DFP DUAL ENCLOSED SHROUD BASE ASSEMBLY

STEP 7

Secure the **Inner back panel** in between the two lower shroud bases using the using the black plastic corner brackets and wood screws provided.

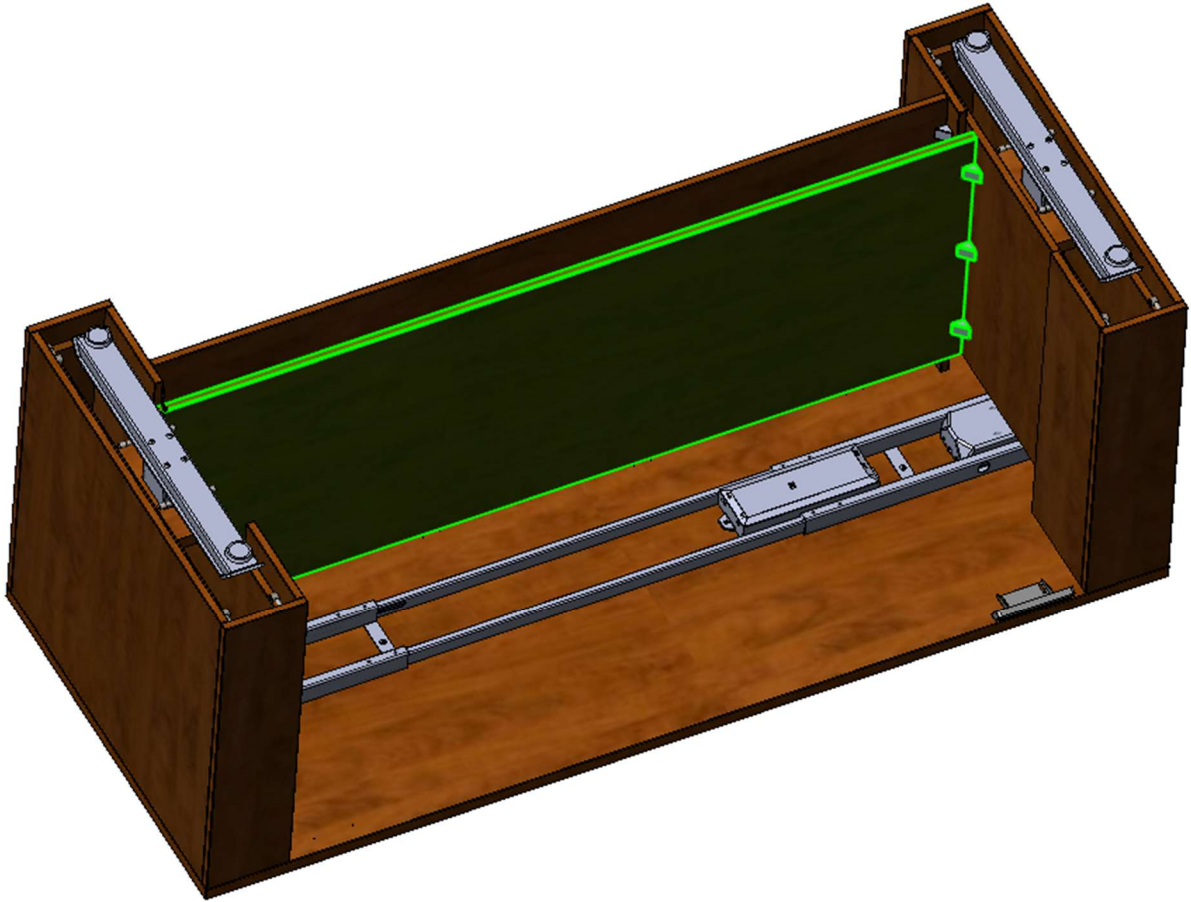

Must leave a gap so back panel does not rub against the base.

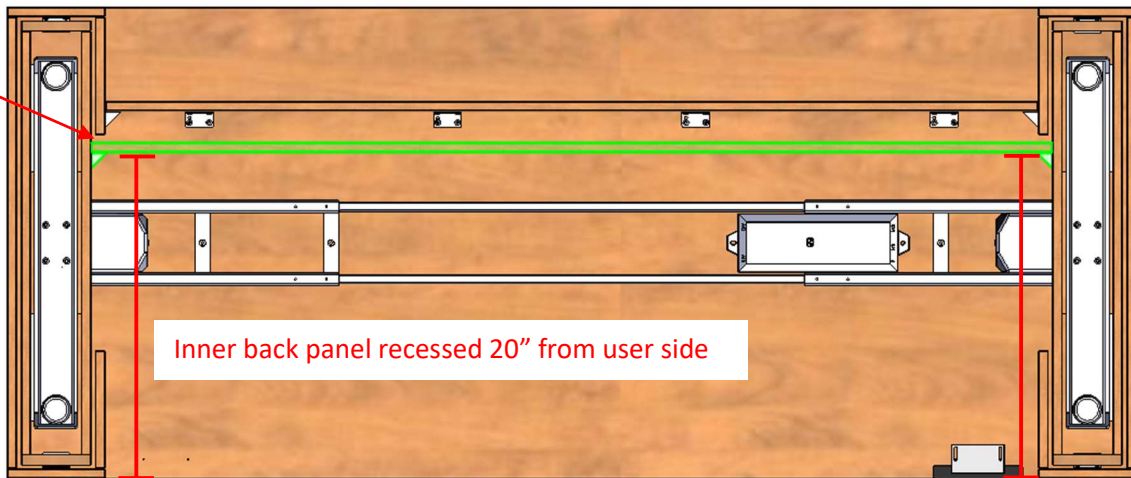

STEP 8

Very carefully rotate the table to its upright position. Make sure to support the lower shroud bases as the table is rotating upwards so they do not slide down forcefully.



Connect the height adjustable base handset and control box and power on the desk.