

HARDWARE

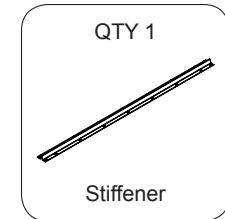

*(Qty 18) #10 x 5/8" screws for a 41-3/4" stiffener
(Qty 22) #10 x 5/8" screws for a 53-3/4" stiffener
(Qty 26) #10 x 5/8" screws for a 65-3/4" stiffener

TOOLS REQUIRED

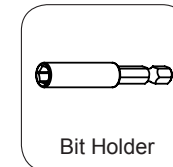

SAFETY WARNINGS

- Failure to place legs in the correct position as shown in these instructions may cause a tipping hazard.
- Two persons required to place table in upright position.
- Use all hardware provided to secure components as specified.

If you have questions, please call OFGO STUDIO Customer Service Toll Free at 1.800.374.3375

1. Place top on soft, clean, scratch resistant surface with the pilot holes facing upwards.
2. Place legs facing top front edge and align the holes on the leg plate with the pilot holes as shown in figure (2a).
Note: on square and round shaped tops only, the legs must be positioned outwards toward the corners as shown in figure (2b).
3. Install #10/12 x 1" long wood screws into the three (3) pilot hole locations on each leg, as shown in figure (3a).
4. Install #10/12 x 1" long wood screws into the five (5) remaining leg plate holes, as shown in figure (4a).

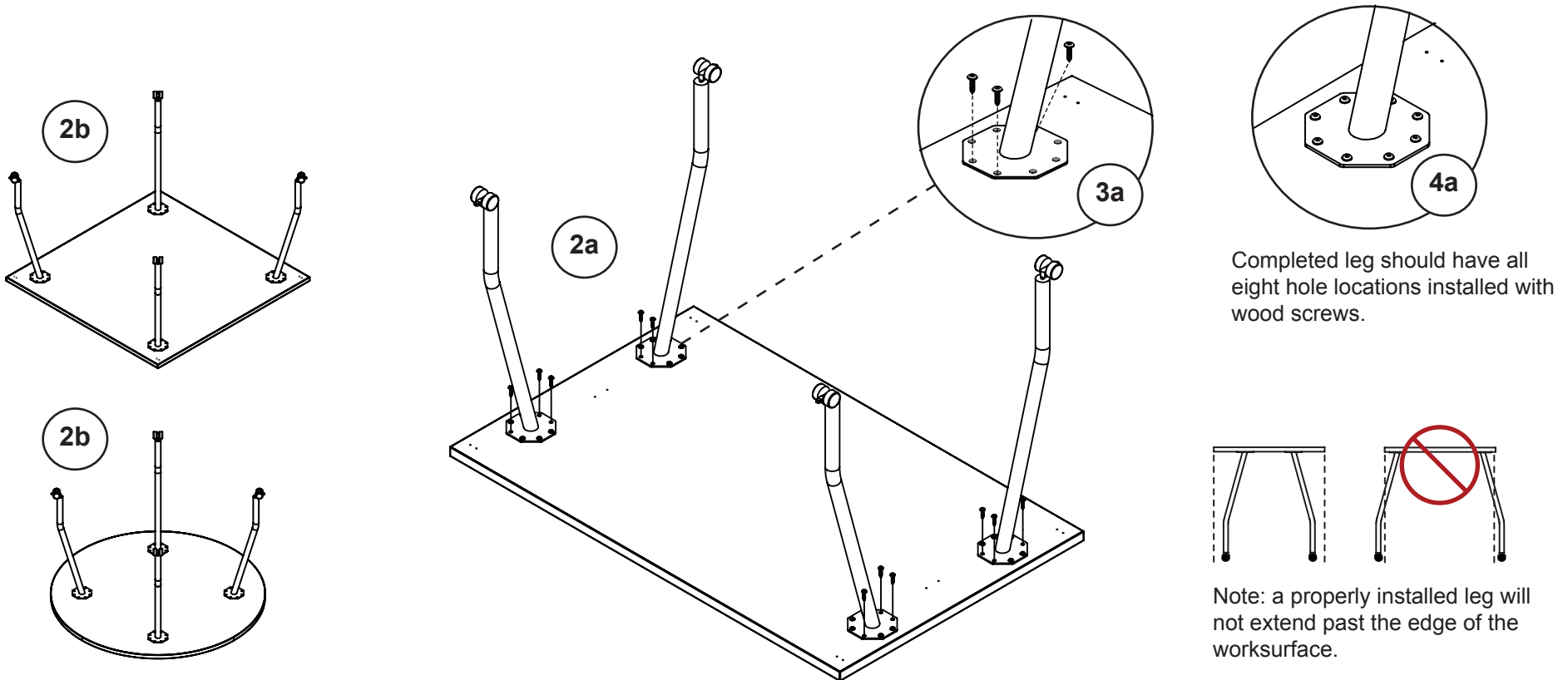

Note: worksurfaces 48" wide and larger contain a stiffener bar which must be installed as per the instructions below. For worksurfaces less than 48" wide no stiffener is required.

- 5.** Align the stiffener bar with the pilot holes, as shown in figure (5a).
- 6.** Install #10 x 5/8" long wood screws into the four (4) pilot hole locations, as shown in figure (6a). Install #10 x 5/8" long wood screws into the remaining stiffener bar hole location, as shown in figure (6b).

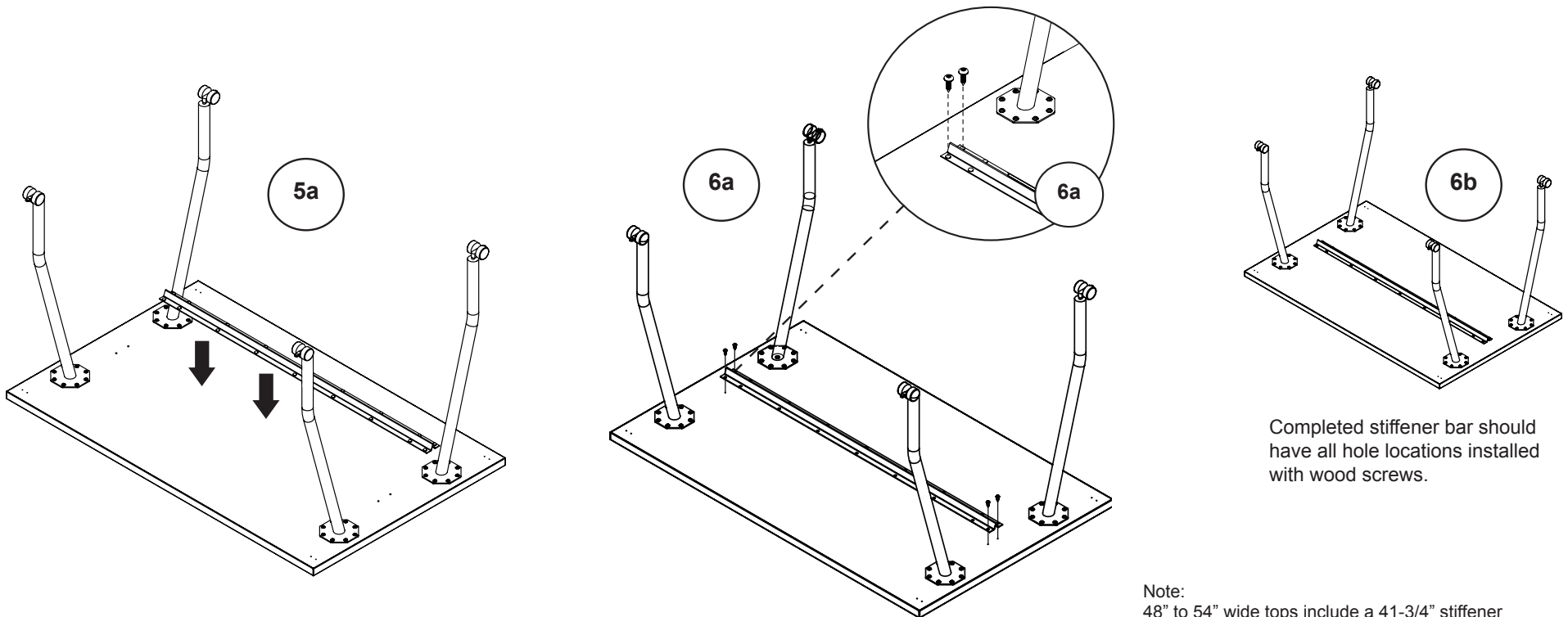

Note:
 48" to 54" wide tops include a 41-3/4" stiffener
 60" to 66" wide tops include a 53-3/4" stiffener
 72" wide tops include a 65-3/4" stiffener

Note: Versatility tables are available with optional table to table connectors that can be installed as per the instructions below.

7. Place table to table connectors on top corners and align with two (2) pilot holes, as shown in figure (7a).

8. Install #8 x 1-3/8" long wood screws into two (2) pilot holes. Install #8 x 1-3/8" long wood screws into the remaining two (2) holes, as shown in figure (7a) and (8a).

