

COMPONENT BREAKDOWN:

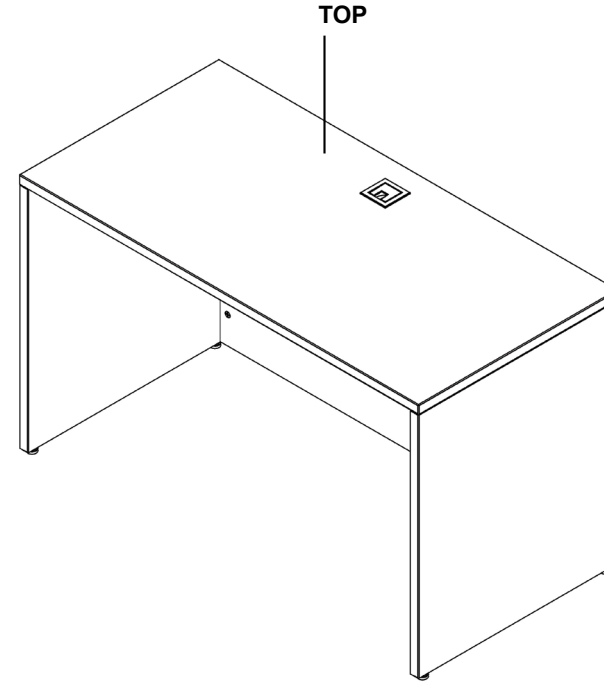

HARDWARE INCLUDED:

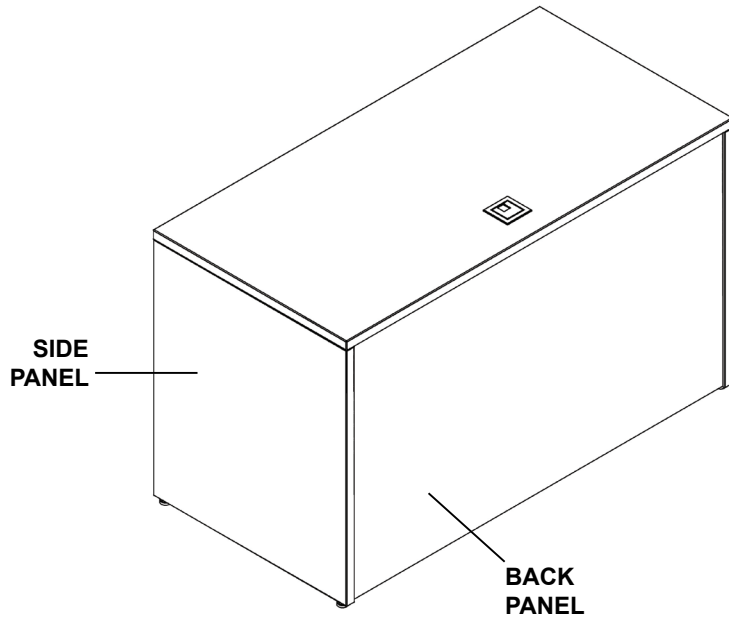

PIN



CAM



COVER
CAP

NOTE: THIS ASSEMBLY INSTRUCTION DISPLAYS A DESK SHELL WITH A FULL HEIGHT (FP) BACK PANEL. IF YOUR ITEM HAS A QUARTER (QP) OR HALF (HP) HEIGHT BACK PANEL INSTEAD THEN THE ASSEMBLY STEPS WILL STILL REMAIN THE SAME.

DISCLAIMERS

- Use all hardware provided to secure components as specified.
- This installation will require 2 or more people.
- Read all instructions and review all illustrations before installing. Failure to observe these warnings could result in injury.
- Product that is damaged by the end user due to misuse, accident, abuse, negligence or shipping is not covered under warranty.

STEP ONE:

Place the BACK PANEL on a soft, clean, scratch-resistant surface, with the pre-drilled holes facing upwards.

Attach the BACK PANEL to the SIDE PANELS using the CAM & PINS provided.

See Figure A for further details on how to assemble with CAM & PIN connectors.

Once all CAMS are tightened apply the COVER CAPS over the CAM holes.

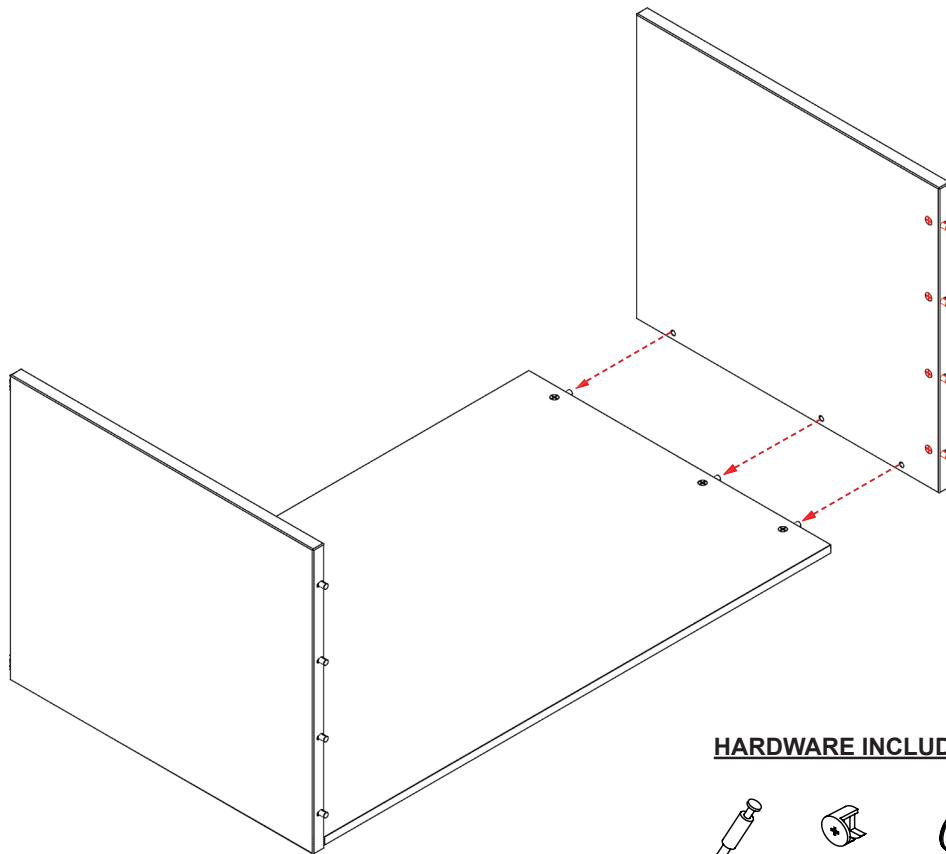

HARDWARE INCLUDED:



Figure A: Cam & Pin Installation

<p>STEP ONE:</p>	<p>Press the Cams into the face of the board.</p> <p>The arrow on the Cam must face the hole where the Pin will enter.</p>
<p>STEP TWO:</p>	<p>Press the Pins into the side of the mating board. Apply hand pressure until the wider collar of each Pin sits flush with the surface.</p>
<p>STEP THREE:</p>	<p>Align the panels so the Pins enter the Cam holes, then press them together firmly until the joint is fully sealed.</p> <p>Using a screwdriver, turn each Cam clockwise approximately $\frac{3}{4}$ of a turn to lock the expanding Pin in place. Avoid overtightening.</p>

Note: Units wider than 72" will have an additional center support panel that will need to be installed in this step.

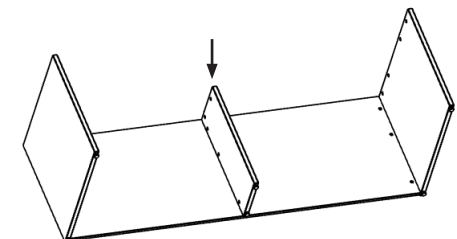

STEP TWO:

Place the TOP on a soft, clean, scratch resistant surface with the pilot holes facing upwards.

If grommets are already present in the surface ensure they are not under any pressure to prevent damage.

Attach the BACK PANEL and SIDE PANELS pre-assembled in STEP ONE to the TOP using the CAM & PINS provided.

See Figure A for further details on how to assemble with CAM & PIN connectors.

Once all CAMS are tightened apply the COVER CAPS over the CAM holes.

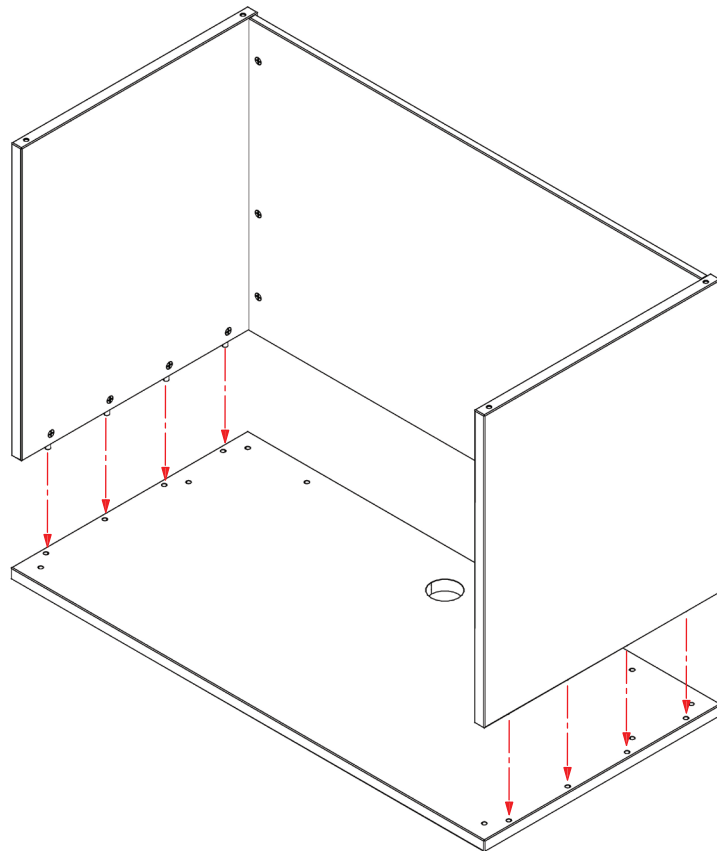

HARDWARE INCLUDED:



Figure A: Cam & Pin Installation

<p>STEP ONE:</p>	<p>Press the Cams into the face of the board.</p> <p>The arrow on the Cam must face the hole where the Pin will enter.</p>
<p>STEP TWO:</p>	<p>Press the Pins into the side of the mating board. Apply hand pressure until the wider collar of each Pin sits flush with the surface.</p>
<p>STEP THREE:</p>	<p>Align the panels so the Pins enter the Cam holes, then press them together firmly until the joint is fully sealed.</p> <p>Using a screwdriver, turn each Cam clockwise approximately $\frac{3}{4}$ of a turn to lock the expanding Pin in place. Avoid overtightening.</p>

Note: Units that are 60" to 72" wide will include an L-Bracket and 5/8" wood screws. Install this L-Bracket at the center of the back panel to secure the back panel to the top.

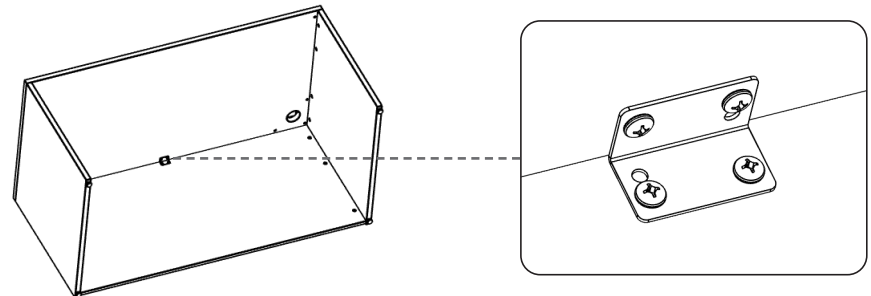

STEP THREE:

If they are not already installed, insert all provided floor levelers into the T-Nuts located on the bottom of the unit.

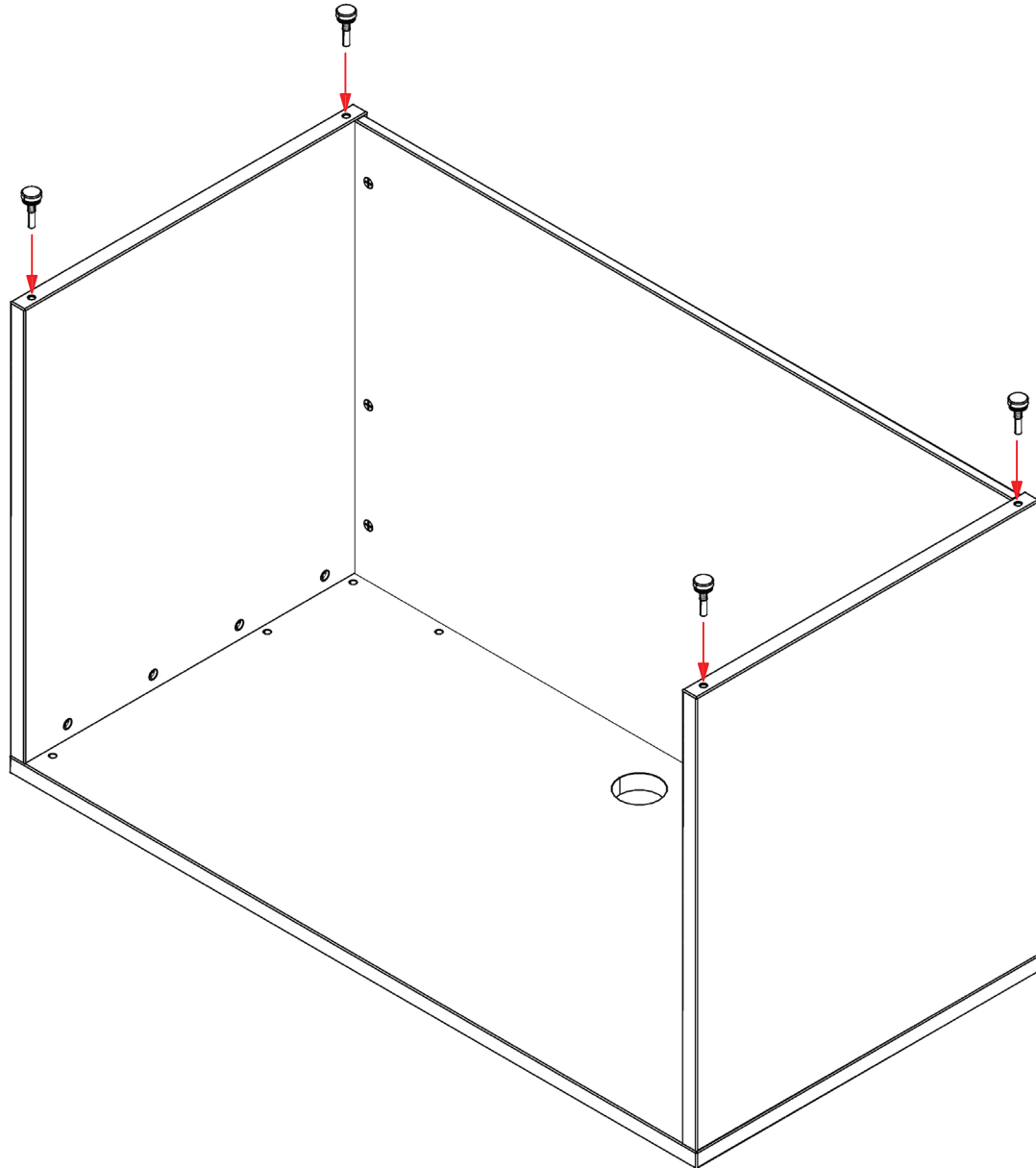

STEP FOUR:

Gently turn the desk shell upright and ensure that all components are properly assembled.

Level the unit as required.

